



IGEN TECH CO.,LTD.

CE EMC REPORT

Prepared For :	IGEN TECH CO.,LTD. A2-B-4, Tian`an iPrk, No.228, Linghu Avenue, Wuxi, Jiangsu, P,R China
Product Name:	THREE-PHASE ENERGY METER
Model :	DTSD422
Prepared By :	BST Testing (Shenzhen) Co.,Ltd. No.7, New Era Industrial Zone, Guantian, Bao'an District, Shenzhen, Guangdong, China
Test Date:	Nov. 13-15, 2019
Date of Report :	Nov. 15, 2019
Report No.:	BSTXD191111697402ER



TABLE OF CONTENTS

TEST REPORT DECLARATION	5
1. TEST RESULTS SUMMARY	6
2. GENERAL INFORMATION	7
2.1. Report information	7
2.2. Measurement Uncertainty	7
3. PRODUCT DESCRIPTION	8
3.1. EUT Description.....	8
3.2. Block Diagram of EUT Configuration	8
3.3. Operating Condition of EUT	8
3.4. Test Conditions.....	8
3.5. Modifications.....	8
3.6. Abbreviations	9
3.7. Performance Criterion	9
4. TEST EQUIPMENT USED	10
4.1. For Conducted Emission Test	10
4.2. For Radiated Emission Measurement.....	10
4.3. For Harmonic / Flicker Test	10
4.4. For Electrostatic Discharge Immunity Test.....	10
4.5. For RF Strength Susceptibility Test	10
4.6. For Electrical Fast Transient/Burst Immunity Test	11
4.7. For Surge Test	11
4.8. For Injected Currents Susceptibility Test	11
4.9. For Magnetic Field Immunity Test.....	11
4.10. For Voltage Dips and Interruptions Test	11
5. POWER LINE CONDUCTED EMISSION TEST	12
5.1. Block Diagram of Test Setup	12
5.2. Test Standard.....	12
5.3. Power Line Conducted Emission Limit	12
5.4. EUT Configuration on Test.....	12
5.5. Operating Condition of EUT	13
5.6. Test Procedure	13
5.7. Test Result.....	13
6. RADIATED EMISSION TEST	14
6.1. Semi-Anechoic Chamber Setup Diagram	14
6.2. Test Standard.....	14
6.3. Radiated Emission Limit	14
6.4. EUT Configuration on Test.....	14
6.5. Operating Condition of EUT	15
6.6. Test Procedure	15
6.7. Test Results	15
7. HARMONIC CURRENT EMISSION TEST	16
7.1. Block Diagram of Test Setup	16
7.2. Test Standard and Limit	16
7.3. Test Procedure	17
7.4. Test Results	17



8. VOLTAGE FLUCTUATIONS & FLICKER TEST	18
8.1. Block Diagram of Test Setup	18
8.2. Test Standard	18
8.3. Operating Condition of EUT	18
8.4. Test Results	18
9. ELECTROSTATIC DISCHARGE TEST	19
9.1. Block Diagram of ESD Test Setup	19
9.2. Test Standard	19
9.3. Severity Levels and Performance Criterion	19
9.4. EUT Configuration on Test	19
9.5. Operating Condition of EUT	20
9.6. Test Procedure	20
9.7. Test Results	20
10. RF FIELD STRENGTH SUSCEPTIBILITY TEST	22
10.1. R/S Test Setup	22
10.2. Test Standard	22
10.3. Severity Levels and Performance Criterion	22
10.4. EUT Configuration on Test	23
10.5. Operating Condition of EUT	23
10.6. Test Procedure	23
10.7. Test Results	23
11. ELECTRICAL FAST TRANSIENT/BURST TEST	25
11.1. EFT Test Setup	25
11.2. Test Standard	25
11.3. Severity Levels and Performance Criterion	25
11.4. EUT Configuration on Test	25
11.5. Operating Condition of EUT	25
11.6. Test Procedure	26
11.7. Test Results	26
12. SURGE TEST	28
12.1. Surge Test Setup	28
12.2. Test Standard	28
12.3. Severity Levels and Performance Criterion	28
12.4. EUT Configuration on Test	28
12.5. Operating Condition of EUT	28
12.6. Test Procedure	29
12.7. Test Results	29
13. INJECTED CURRENTS SUSCEPTIBILITY TEST	31
13.1. Block Diagram of Test AC Mains Setup	31
13.2. Test Standard	31
13.3. Severity Levels and Performance Criterion	31
13.4. EUT Configuration on Test	31
13.5. Operating Condition of EUT	32
13.6. Test Procedure	32
13.7. Test Results	32
14. VOLTAGE DIPS AND INTERRUPTIONS TEST	34
14.1. Voltage Dips and Interruptions Test Setup	34
14.2. Test Standard	34



14.3. Severity Levels and Performance Criterion.....	34
14.4. EUT Configuration on Test.....	34
14.5. Operating Condition of EUT.....	34
14.6. Test Procedure.....	35
14.7. Test Result.....	35
APPENDIX I	37
APPENDIX II.....	40
APPENDIX III.....	43



TEST REPORT DECLARATION

Applicant	:	IGEN TECH CO.,LTD.
Address	:	A2-B-4, Tian'an iPrk, No.228, Linghu Avenue, Wuxi, Jiangsu, P,R China
EUT Description	:	THREE-PHASE ENERGY METER
Model Number	:	DTSD422

Test Standards:

EN61326-1:2013

EN61000-3-2:2014

EN61000-3-3:2013

The EUT described above is tested by BST Testing (Shenzhen) Co.,Ltd. EMC Laboratory to determine the maximum emissions from the EUT and ensure the EUT to be compliance with the immunity requirements of the EUT. BST Testing (Shenzhen) Co.,Ltd. EMC Laboratory is assumed full responsibility for the accuracy of the test results. Also, this report shows that the EUT technically complies with the 2014/30/EU directive and its amendment requirements.

The test report is valid for above tested sample only and shall not be reproduced in part without written approval of the laboratory.

Prepared by :

pinko

Assistant

Tested by :

Toby Zhong

Test Engineer

Reviewer :

Tom chen

Approved & Authorized Signer :



Supervisor
General Manager



1. TEST RESULTS SUMMARY

Table 1 Test Results Summary

Test Items	Test Results
Power Line Conducted Emission Test	PASS
Radiated Emission Test	PASS
Harmonic Current Emission Test	PASS
Voltage Fluctuations & Flicker Test	PASS
Electrostatic Discharge Test	PASS
RF Field Strength Susceptibility Test	PASS
Electrical Fast Transient/Burst Test	PASS
Surge Test	PASS
Injected Currents Susceptibility Test	PASS
Voltage Dips And Interruptions Test	PASS



2. GENERAL INFORMATION

2.1. Report information

- 2.1.1. This report is not a certificate of quality; it only applies to the sample of the specific product/equipment given at the time of its testing. The results are not used to indicate or imply that they are application to the similar items. In addition, such results must not be used to indicate or imply that BST approves recommends or endorses the manufacture, supplier or use of such product/equipment, or that BST in any way guarantees the later performance of the product/equipment.
- 2.1.2. The sample/s mentioned in this report is/are supplied by Applicant, BST therefore assumes no responsibility for the accuracy of information on the brand name, model number, origin of manufacture or any information supplied.
- 2.1.3. Additional copies of the report are available to the Applicant at an additional fee. No third part can obtain a copy of this report through BST, unless the applicant has authorized BST in writing to do so.

2.2. Measurement Uncertainty

(95% confidence levels, $k=2$)

Test Item	Uncertainty
Uncertainty for Conduction emission test	2.2dB
Uncertainty for Radiation emission test (30MHz to 1GHz)	4.0dB



3. PRODUCT DESCRIPTION

3.1. EUT Description

Description	:	THREE-PHASE ENERGY METER
Applicant	:	IGEN TECH CO.,LTD. A2-B-4, Tian`an iPrk, No.228, Linghu Avenue, Wuxi, Jiangsu, P,R China
Manufacturer	:	WUXI HENGTONG ELECTRONIC DEVICE CO., LTD. No. 68 East ZhouXin Road, Taihu Town, Binhu District, Wuxi City, Jiangsu Province, China
Model Number	:	DTSD422

3.2. Block Diagram of EUT Configuration

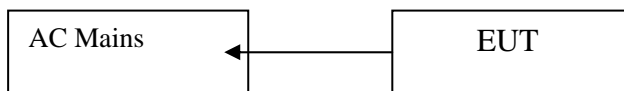

3.3. Operating Condition of EUT

Test mode 1: On

3.4. Test Conditions

Temperature: 23-26°C

Relative Humidity: 55-68 %

3.5. Modifications

No modification was made.



3.6. Abbreviations

AC	Alternating Current
AMN	Artificial Mains Network
DC	Direct Current
EM	ElectroMagnetic
EMC	ElectroMagnetic Compatibility
EUT	Equipment Under Test
IF	Intermediate Frequency
RF	Radio Frequency
rms	root mean square
EMI	Electromagnetic Interference
EMS	Electromagnetic Susceptibility

3.7. Performance Criterion

Criterion A: The equipment shall continue to operate as intended without operator intervention. No degradation of performance or loss of function is allowed below a performance level specified by the manufacturer when the equipment is used as intended.

Criterion B: After the test, the equipment shall continue to operate as intended without operator intervention. No degradation of performance or loss of function is allowed, after the application of the phenomena below a performance level specified by the manufacturer, when the equipment is used as intended.

Criterion C: Loss of function is allowed, provided the function is self-recoverable, or can be restored by the operation of the controls by the user in accordance with the manufacturer's instructions.



4. T EQUIPMENT USED

4.1. For Conducted Emission Test

Item	Equipment	Manufacturer	Model No.	Serial No.	Last Cal.	Cal. Interval
1.	Test Receiver	Rohde & Schwarz	ESHS30	828985/018	Oct. 08, 2019	1 Year
2.	Pulse Limiter	Rohde & Schwarz	ESH3-Z2	100006	Oct. 08, 2019	1 Year
3.	L.I.S.N.	Rohde & Schwarz	ESH2-Z5	834549/005	Oct. 08, 2019	1 Year
4.	Conical	Emtek	N/A	N/A	N/A	N/A
5.	Voltage Probe	Schwarzbeck	TK9416	N/A	Oct. 08, 2019	1 Year
6.	Coaxial Switch	Anritsu	MP59B	6100214550	Oct. 08, 2019	1 Year

4.2. For Radiated Emission Measurement

Item	Equipment	Manufacturer	Model No.	Serial No.	Last Cal.	Cal. Interval
1.	Spectrum Analyzer	ANRITSU	MS2661C	6200140915	Oct. 08, 2019	1 Year
2.	Test Receiver	Rohde&Schwarz	ESC830	828982/018	Oct. 08, 2019	1 Year
3.	Bilog Antenna	Schwarzbeck	VULB9163	142	Oct. 08, 2019	1 Year
4.	50 Coaxial Switch	Anritsu Corp	MP59B	6100237248	Oct. 08, 2019	1 Year
5.	Cable	Schwarzbeck	AK9513	ACRX1	Oct. 08, 2019	1 Year
6.	Cable	Rosenberger	N/A	FR2RX2	Oct. 08, 2019	1 Year
7.	Cable	Schwarzbeck	AK9513	CRRX2	Oct. 08, 2019	1 Year
8.	Cable	Schwarzbeck	AK9513	CRRX2	Oct. 08, 2019	1 Year
9.	Signal Generator	HP	864A	3625U00573	Oct. 08, 2019	1 Year

4.3. For Harmonic / Flicker Test

Item	Equipment	Manufacturer	Model No.	Serial No.	Last Cal.	Cal. Interval
1.	Harmonic and Flicker analyzer	Laplace	AC2000A	309709	Oct. 08, 19	1 Year

4.4. For Electrostatic Discharge Immunity Test

Item	Equipment	Manufacturer	Model No.	Serial No.	Last Cal.	Cal. Interval
1.	ESD Tester	HAEFELY	PSD 1600	H911'292	Oct. 08, 19	1 Year

4.5. For RF Strength Susceptibility Test

Item	Equipment	Manufacturer	Model No.	Serial No.	Last Cal.	Cal. Interval
1.	Signal Generator	HP	8648A	3633A02081	Oct. 08, 19	1 Year
2.	Amplifier	A&R	500A100	17034	NCR	NCR
3.	Amplifier	A&R	100W/1000M1	17028	NCR	NCR
4.	Isotropic Field Monitor	A&R	FM2000	16829	NCR	NCR
5.	Isotropic Field Probe	A&R	FLW220100	16755	Oct. 08, 19	1 Year
6.	Biconic Antenna	EMCO	3108	9507-2534	NCR	NCR
7.	Log-periodic Antenna	A&R	AT1080	16812	NCR	NCR
8.	PC	N/A	486DX2	N/A	N/A	N/A



4.6. For Electrical Fast Transient/Burst Immunity Test

Item	Equipment	Manufacturer	Model No.	Serial No.	Last Cal.	Cal. Interval
1.	Burst Tester	HAEFELY	PEFT 4010	080981-16	Oct. 08, 2019	1 Year

4.7. For Surge Test

Item	Equipment	Manufacturer	Model No.	Serial No.	Last Cal.	Cal. Interval
1.	Surge Tester	HAEFELY	PSURGE4.1	080107-04	Oct. 08, 2019	1 Year

4.8. For Injected Currents Susceptibility Test

Item	Equipment	Manufacturer	Model No.	Serial No.	Last Cal.	Cal. Interval
1.	Simulator	EMTEST	CWS 500C	0900-12	Oct. 08, 2019	1 Year
2.	CDN	EMTEST	CDN-M2	510010010010	Oct. 08, 2019	1 Year
3.	VDN	EMTEST	CDN-M3	0900-11	Oct. 08, 2019	1 Year
4.	Injection Clamp	EMTEST	F-2031-23MM	368	Oct. 08, 2019	1 Year
5.	Attenuator	EMTEST	ATT6	0010222a	Oct. 08, 2019	1 Year

4.9. For Magnetic Field Immunity Test

Item	Equipment	Manufacturer	Model No.	Serial No.	Last Cal.	Cal. Interval
1.	Magnetic Field Tester	HAEFELY	MAG100.1	083858-10	Oct. 08, 2019	1 Year

4.10. For Voltage Dips and Interruptions Test

Item	Equipment	Manufacturer	Model No.	Serial No.	Last Cal.	Cal. Interval
1.	Dips Tester	HAEFELY	PLINE 1610	083732-18	Oct. 08, 2019	1 Year

5. POWER LINE CONDUCTED EMISSION TEST

5.1. Block Diagram of Test Setup

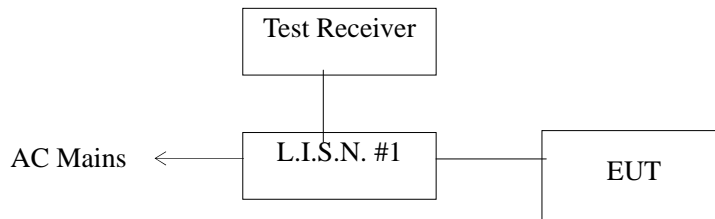

5.2. Test Standard

EN61326-1:2013

5.3. Power Line Conducted Emission Limit

Frequency MHz	Limits dB(μV)	
	Quasi-peak Level	Average Level
0.15 ~ 0.50	66 ~ 56*	56 ~ 46*
0.50 ~ 5.00	56	46
5.00 ~ 30.00	60	50

Notes: 1. *Decreasing linearly with logarithm of frequency.

2. The lower limit shall apply at the transition frequencies.

5.4. EUT Configuration on Test

The following equipments are installed on conducted emission test to meet EN61326-1 requirement and operating in a manner, which tends to maximize its emission characteristics in a normal application.

5.4.1. EUT Information

Model Number : DTSD422
 Serial Number : N/A
 Manufacturer : WUXI HENGTONG ELECTRONIC DEVICE CO., LTD.



5.5. Operating Condition of EUT

- 5.5.1. Setup the EUT and simulators as shown in Section 5.1.
- 5.5.2. Turn on the power of all equipments.
- 5.5.3. Let the EUT work in test modes (ON) and test it.

5.6. Test Procedure

The EUT is put on the ground and connected to the AC mains through a Artificial Mains Network (AMN). This provided 50ohm-coupling impedance for the tested equipments. Both sides of AC line are checked to find out the maximum conducted emission levels according to the EN61326-1 regulations during conducted emission test.

The bandwidth of the test receiver is set at 9kHz.

The frequency range from 150 KHz to 30 MHz is investigated. and all the scanning waveform is put in **Appendix I**.

5.7. Test Result

PASS.

6. RADIATED EMISSION TEST

6.1. Semi-Anechoic Chamber Setup Diagram

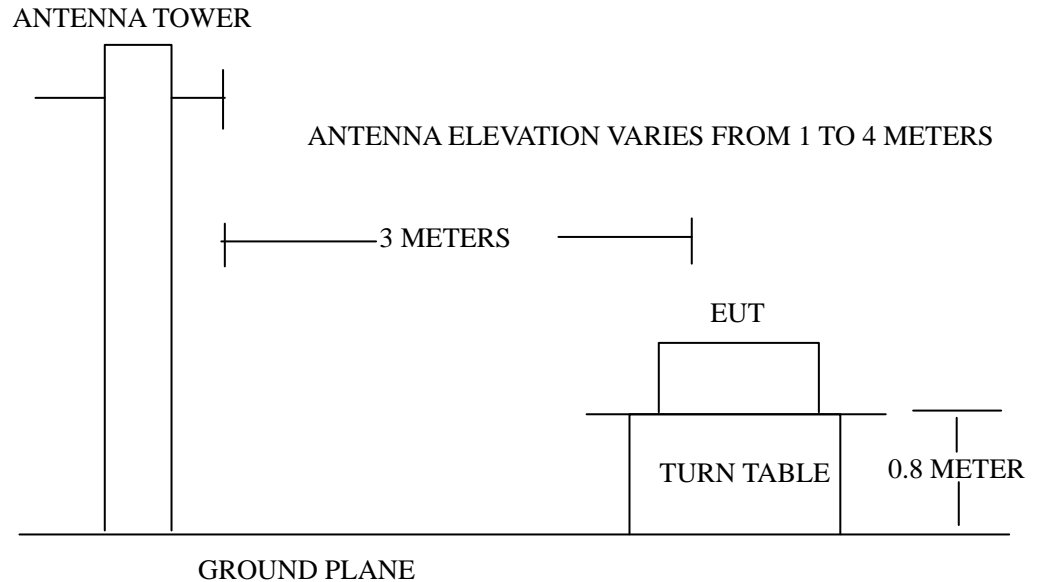

6.2. Test Standard

EN61326-1:2013

6.3. Radiated Emission Limit

All emanations from a Class B computing devices or system, including any network of conductors and apparatus connected thereto, shall not exceed the level of field strengths specified below:

FREQUENCY (MHz)	DISTANCE (Meters)	FIELD STRENGTHS LIMITS (dB μ V/m)
30 ~ 230	3	40
230 ~ 1000	3	47

Note:(1) The tighter limit shall apply at the edge between two frequency bands.

(2) Distance refers to the distance in meters between the measuring instruments antenna and the closed point of any part of the EUT.

6.4. EUT Configuration on Test

The EN61326-1 Class B regulations test method must be used to find the maximum emission during radiated emission test.



6.5. Operating Condition of EUT

- 6.5.1. Setup the EUT as shown on Section 6.1.
- 6.5.2. Turn on the power of all equipments.
- 6.5.3. Let the EUT work in test mode(On) and measure it.

6.6. Test Procedure

The EUT is placed on a turn table which is 0.8 meter above ground. The turn table can rotate 360 degrees to determine the position of the maximum emission level. The EUT is set 3 meters away from the receiving antenna which is mounted on a antenna tower. The antenna can move up and down between 1 to 4 meters to find out the maximum emission level. Broadband antenna (calibrated by dipole antenna) are used as a receiving antenna. Both horizontal and vertical polarization of the antenna are set on test.

The bandwidth setting on the test receiver is 120 KHz.

The EUT is tested in Semi-Anechoic Chamber. and all the scanning waveform is put in **Appendix II.**

6.7. Test Results

PASS.

7. HARMONIC CURRENT EMISSION TEST

7.1. Block Diagram of Test Setup

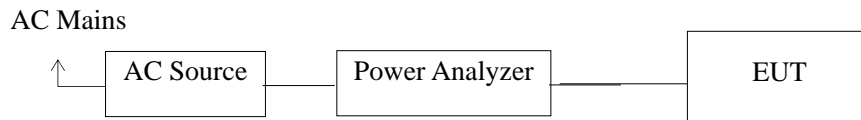

7.2. Test Standard and Limit

7.2.1. Test Standard

EN61000-3-2:2014

7.2.2. Limits

Table 12 Harmonic Current Test Limit (Class A)

Harmonic order (n)	Maximum permissible harmonic current (A)
Odd harmonics	
3	2.30
5	1.14
7	0.77
9	0.40
11	0.33
13	0.21
$15 \leq n \leq 39$	$0.15 \times 15/n$
Even harmonics	
2	1.08
4	0.43
6	0.30
$8 \leq n \leq 40$	$0.23 \times 8/n$



7.3. Test Procedure

The power cord of the EUT is connected to the output of the test system. Turn on the Power of the EUT and use the test system to test the harmonic current level.

7.4. Test Results

PASS.



8. VOLTAGE FLUCTUATIONS & FLICKER TEST

8.1. Block Diagram of Test Setup

Same as Section 7.1..

8.2. Test Standard

EN61000-3-3:2013

8.3. Operating Condition of EUT

Same as Section 7.3.. The power cord of the EUT is connected to the output of the test system. Turn on the power of the EUT and use the test system to test.

Flicker Test Limit

Test items	Limits
Pst	1.0
dc	3.3%
dmax	4.0%
dt	Not exceed 3.3% for 500ms

8.4. Test Results

PASS.

9. ELECTROSTATIC DISCHARGE TEST

9.1. Block Diagram of ESD Test Setup

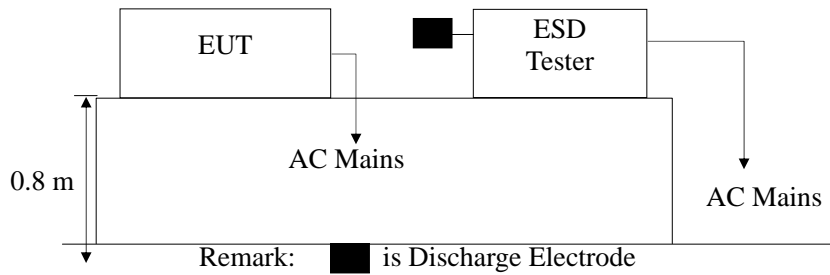

9.2. Test Standard

EN61326-1:2013 (EN61000-4-2:2009)

Severity Level 3 for Air Discharge at 8KV

Severity Level 2 for Contact Discharge at 4KV

9.3. Severity Levels and Performance Criterion

9.3.1. Severity level

Level	Test Voltage Contact Discharge (KV)	Test Voltage Air Discharge (KV)
1.	2	2
2.	4	4
3.	6	8
4.	8	15
X.	Special	Special

9.3.2. Performance criterion: B

9.4. EUT Configuration on Test

The configuration of EUT are listed in Section 3.2.



9.5. Operating Condition of EUT

- 9.5.1. Setup the EUT as shown in Section 9.1.
- 9.5.2. Turn on the power of all equipments.
- 9.5.3. Let the EUT work in test mode (on) and test it.

9.6. Test Procedure

9.6.1. Air Discharge:

This test is done on a non-conductive surfaces. The round discharge tip of the discharge electrode shall be approached as fast as possible to touch the EUT.

After each discharge, the discharge electrode shall be removed from the EUT.

The generator is then re-triggered for a new single discharge and repeated 10 times for each pre-selected test point. This procedure shall be repeated until all the air discharge completed.

9.6.2. Contact Discharge:

All the procedure shall be same as Section 9.6.1. except that the tip of the discharge electrode shall touch the EUT before the discharge switch is operated.

9.6.3. Indirect discharge for horizontal coupling plane

At least 20 single discharges shall be applied to the horizontal coupling plane, at points on each side of the EUT. The discharge electrode positions vertically at a distance of 0.1m from the EUT and with the discharge electrode touching the coupling plane.

9.6.4. Indirect discharge for vertical coupling plane

At least 20 single discharge shall be applied to the center of one vertical edge of the coupling plane. The coupling plane, of dimensions 0.5m X 0.5m, is placed parallel to, and positioned at a distance of 0.1m from the EUT. Discharges shall be applied to the coupling plane, with this plane in sufficient different positions that the four faces of the EUT are completely illuminated.

9.7. Test Results

PASS.

Please refer to the following page.



Electrostatic Discharge Test Results

BST Testing (Shenzhen) Co.,Ltd.

<p><i>Applicant</i> : IGEN TECH CO.,LTD.</p> <hr/> <p><i>EUT</i> : THREE-PHASE ENERGY METER</p> <hr/> <p><i>M/N</i> : DTSD422</p> <hr/> <p><i>Power Supply</i> : -</p> <hr/> <p><i>Test Engineer</i> :</p>	<p><i>Test Date</i> : Nov. 13, 2019</p> <hr/> <p><i>Temperature</i> : 22 °C</p> <hr/> <p><i>Humidity</i> : 50 %</p> <hr/> <p><i>Test Mode</i> : ON</p> <hr/>	
<p><i>Air Discharge: ±8KV</i> <i>For each point positive 10 times and negative 10 times discharge.</i></p> <p><i>Contact Discharge: ±4KV</i></p>		
<i>Location</i>	<i>Kind</i> A-Air Discharge C-Contact Discharge	<i>Result</i>
<i>Slots</i>	A	PASS
<i>Metal parts</i>	C	PASS
<i>HCP</i>	C	PASS
<i>VCP</i>	C	PASS

Discharge should be considered on Contact and Air and Horizontal Coupling Plane (HCP) and Vertical Coupling Plane (VCP).

10. RF FIELD STRENGTH SUSCEPTIBILITY TEST

10.1.R/S Test Setup

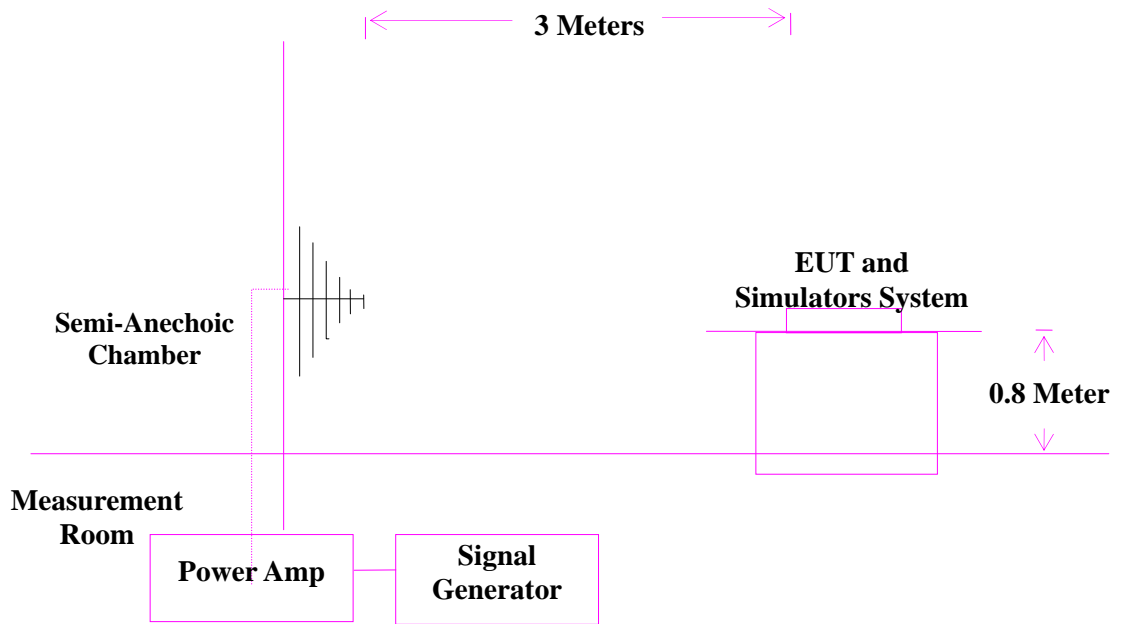

10.2.Test Standard

EN61326-1:2013 (EN 61000-4-3:2006 + A1:2008 + A2:2010)
Severity Level 2 at 3V / m

10.3.Severity Levels and Performance Criterion

10.3.1.Severity level

Level	Field Strength V/m
1.	1
2.	3
3.	10
X.	Special

10.3.2.Performance criterion : A



10.4.EUT Configuration on Test

The configuration of EUT are listed in Section 3.2

10.5.Operating Condition of EUT

Setup the EUT as shown in Section 10.1.. The operating condition of EUT are listed in section 3.3.

10.6.Test Procedure

The EUT and its simulators are placed on a turn table which is 0.8 meter above the ground. The EUT is set 3 meters away from the transmitting antenna which is mounted on an antenna tower. Both horizontal and vertical polarization of the antenna are set on test. Each of the four sides of EUT must be faced this transmitting antenna and measured individually. In order to judge the EUT performance, a CCD camera is used to monitor the EUT. All the scanning conditions are as follows :

Condition of Test	Remarks
1. Fielded Strength	3 V/m (Severity Level 2)
2. Radiated Signal	Modulated
3. Scanning Frequency	80 - 1000 MHz,1.4GHz-2.7GHz
4. Sweeping time of radiated	0.0015 decade/s
5. Dwell Time	1 Sec.

10.7.Test Results

PASS.

Please refer to the following page.



RF Field Strength Susceptibility Test Results

BST Testing (Shenzhen) Co.,Ltd.

<i>Applicant</i> : IGEN TECH CO.,LTD.	<i>Test Date</i> : Nov. 13, 2019	
<i>EUT</i> : THREE-PHASE ENERGY METER	<i>Temperature</i> : 22 °C	
<i>M/N</i> : DTSD422	<i>Humidity</i> : 50 %	
<i>Power Supply</i> : -	<i>Test Mode</i> : ON	
<i>Test Engineer</i> :	<i>Frequency Range</i> : 80 MHz to 1000 MHz 1.4GHz to 2.7GHz	
<i>Modulation:</i> <input checked="" type="checkbox"/> AM <input type="checkbox"/> Pulse <input type="checkbox"/> none 1 KHz 80%		
<i>Criterion</i> : A		
	<i>Frequency Rang</i> : 80-1000	
<i>Steps</i>	1%	1%
	<i>Horizontal</i>	<i>Vertical</i>
<i>Front</i>	Pass	Pass
<i>Right</i>	Pass	Pass
<i>Rear</i>	Pass	Pass
<i>Left</i>	Pass	Pass

11.ELECTRICAL FAST TRANSIENT/BURST TEST

11.1.EFT Test Setup

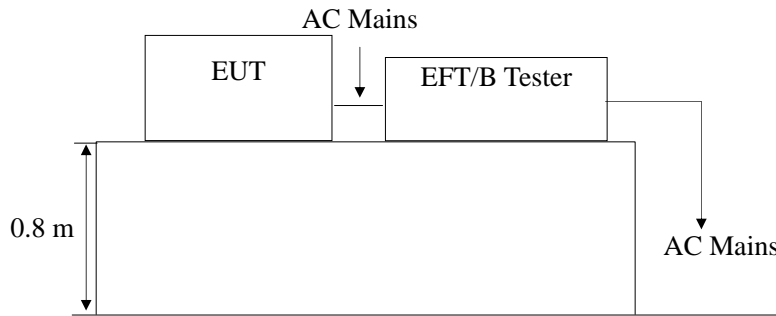

11.2.Test Standard

EN61326-1:2013 (EN61000-4-4:2012)
Severity Level 2 at 1KV(5/50 ns, 5 kHz)

11.3.Severity Levels and Performance Criterion

11.3.1.Severity level

Level	Open Circuit Output Test Voltage $\pm 10\%$	
	On Power Supply Lines	On I/O (Input/Output) Signal data and control lines
1.	0.5 KV	0.25 KV
2.	1 KV	0.5 KV
3.	2 KV	1 KV
4.	4 KV	2 KV
X	Special	Special

11.3.2.Performance criterion : B

11.4.EUT Configuration on Test

The configuration of EUT are listed in Section 3.2..

11.5.Operating Condition of EUT

Setup the EUT as shown in Section 11.1.. The operating condition of EUT are listed in section 3.3.



11.6. Test Procedure

The EUT is put on the table which is 0.8 meter high above the ground. This reference ground plane shall project beyond the EUT by at least 0.1m on all sides and the minimum distance between the EUT and all other conductive structure, except the ground plane beneath the EUT, shall be more than 0.5m.

11.6.1. For input and output AC power ports:

The EUT is connected to the power mains by using a coupling device which couples the EFT interference signal to AC power lines. Both polarities of the test voltage should be applied during compliance test and the duration of the test is 2 mins.

11.6.2. For signal lines and control lines ports:

It's unnecessary to test.

11.6.3. For DC output line ports:

It's unnecessary to test.

11.7. Test Results

PASS.



Electrical Fast Transient/Burst Test Results

BST Testing (Shenzhen) Co.,Ltd.

<i>Applicant</i> : IGEN TECH CO.,LTD.		<i>Test Date</i> : Nov. 13, 2019							
<i>EUT</i> : THREE-PHASE ENERGY METER		<i>Temperature</i> : 22 °C							
<i>M/N</i> : DTSD422		<i>Humidity</i> : 50 %							
<i>Power Supply</i> : -		<i>Test Mode</i> : ON							
<i>Test Engineer</i> :									
<i>Inject Place</i> : AC Mains									
<i>Inject Line</i>	<i>Voltage KV</i>	<i>Inject Time(s)</i>	<i>Inject Method</i>	<i>Results</i>	<i>Inject Line</i>	<i>Voltage KV</i>	<i>Inject Time(s)</i>	<i>Inject Method</i>	<i>Results</i>
L	±1KV (5/50 ns, 5 kHz)	120	Direct	PASS					
N	±1KV (5/50 ns, 5 kHz)	120	Direct	PASS					
L N	±1KV (5/50 ns, 5 kHz)	120	Direct	PASS					

12.SURGE TEST

12.1.Surge Test Setup

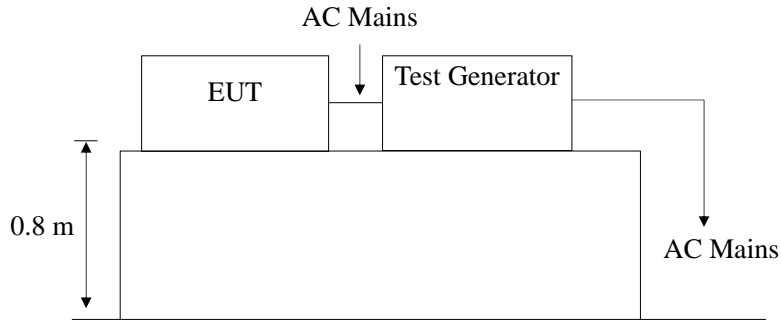

12.2.Test Standard

EN61326-1:2013 (EN61000-4-5:2014)
Severity Level 2 for Line to Neutral at 0.5 kVa/1 kVb

12.3.Severity Levels and Performance Criterion

12.3.1.Severity level

Severity Level	Open-Circuit Test Voltage KV
1	0.5
2	1.0
3	2.0
4	4.0
*	Special

Performance criterion : **C**

12.4.EUT Configuration on Test

The configuration of EUT are listed in Section 3.2.

12.5.Operating Condition of EUT

- 12.5.1.Setup the EUT as shown in Section 12.1..
- 12.5.2.Turn on the power of all equipments.
- 12.5.3.Let the EUT work in test mode (on) and test it.



12.6. Test Procedure

- 1) Setup the EUT and test generator as shown on Section 12.1.
- 2) For line to line coupling mode, provide a 0.5KV 1.2/50us voltage surge (at open-circuit condition) and 8/20us current surge to EUT selected points.
- 3) At least 5 positive and 5 negative (polarity) tests with a maximum 1/min repetition rate are conducted during test.
- 4) Different phase angles are done individually.
- 5) Record the EUT operating situation during compliance test and decide the EUT immunity criterion for above each test.

12.7. Test Results

PASS.



Surge Immunity Test Results

BST Testing (Shenzhen) Co.,Ltd.

<i>Applicant</i> : IGEN TECH CO.,LTD.				<i>Test Date</i> : Nov. 13, 2019	
<i>EUT</i> : THREE-PHASE ENERGY METER				<i>Temperature</i> : 22 °C	
<i>M/N</i> : DTSD422				<i>Humidity</i> : 50 %	
<i>Power Supply</i> : -				<i>Test Mode</i> : ON	
<i>Test Engineer</i> :					
<i>Location</i>	<i>Polarity</i>	<i>Phase Angle</i>	<i>No of Pulse</i>	<i>Pulse Voltage (KV)</i>	<i>Result</i>
<i>L-N</i>	+	0	5	0.5 kV/1 kV	PASS
	+	90	5	0.5 kV/1 kV	PASS
	+	180	5	0.5 kV/1 kV	PASS
	+	270	5	0.5 kV/1 kV	PASS
	-	0	5	0.5 kV/1 kV	PASS
	-	90	5	0.5 kV/1 kV	PASS
	-	180	5	0.5 kV/1 kV	PASS
	-	270	5	0.5 kV/1 kV	PASS

13.INJECTED CURRENTS SUSCEPTIBILITY TEST

13.1.Block Diagram of Test AC Mains Setup

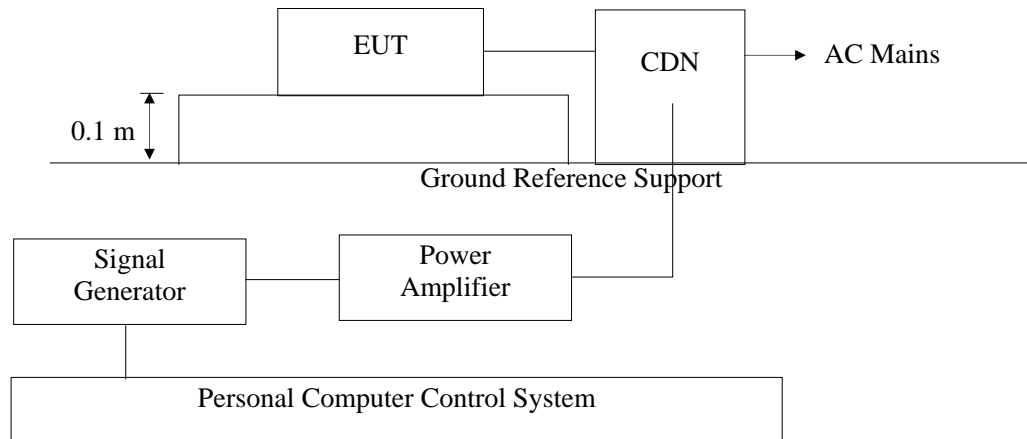

13.2.Test Standard

EN61326-1:2013 (EN61000-4-6:2014)

Severity Level 2 at 1 V (rms), 0.15MHz ~ 80MHz

13.3.Severity Levels and Performance Criterion

13.3.1.Severity level

Level	Field Strength V/m
1.	1
2.	3
3.	10
X	Special

13.3.2.Performance criterion: A

13.4.EUT Configuration on Test

The configuration of EUT are listed in Section 3.2



13.5.Operating Condition of EUT

Setup the EUT as shown in Section 13.1.. The operating condition of EUT are listed in section 3.3

13.6.Test Procedure

- 1) Set up the EUT, CDN and test generators as shown on Section 13.1.
- 2) Let the EUT work in test mode and test it.
- 3) The EUT are placed on an insulating support 0.8m high above a ground reference plane. CDN (coupling and decoupling device) is placed on the ground plane about 0.3m from EUT. Cables between CDN and EUT are as short as possible, and their height above the ground reference plane shall be between 30 and 50 mm (where possible).
- 4) The disturbance signal described below is injected to EUT through CDN.
- 5) The EUT operates within its operational mode(s) under intended climatic conditions after power on.
- 6) The frequency range is swept from 150KHz to 80MHz using 1V signal level, and with the disturbance signal 80% amplitude modulated with a 1KHz sine wave.
- 7) The rate of sweep shall not exceed 1.5×10^{-3} decades/s. Where the frequency is swept incrementally, the step size shall not exceed 1% of the start and thereafter 1% of the preceding frequency value.
- 8) Recording the EUT operating situation during compliance testing and decide the EUT immunity criterion.

13.7.Test Results

PASS .



Injected Currents Susceptibility Test Results

BST Testing (Shenzhen) Co.,Ltd.

<i>Applicant</i> : IGEN TECH CO.,LTD.		<i>Test Date</i> : Nov. 13, 2019		
<i>EUT</i> : THREE-PHASE ENERGY METER		<i>Temperature</i> : 22 °C		
<i>M/N</i> : DTSD422		<i>Humidity</i> : 50 %		
<i>Power Supply</i> : -		<i>Test Mode</i> : ON		
<i>Test Engineer</i> :				
<i>Frequency Range (MHz)</i>	<i>Injected Position</i>	<i>Strength</i>	<i>Criterion</i>	<i>Result</i>
0.15 ~ 20	AC Line	<i>IV(rms), Unmodulated</i>	A	PASS
20 ~ 80	AC Line	<i>IV(rms), Unmodulated</i>	A	PASS

14. VOLTAGE DIPS AND INTERRUPTIONS TEST

14.1. Voltage Dips and Interruptions Test Setup

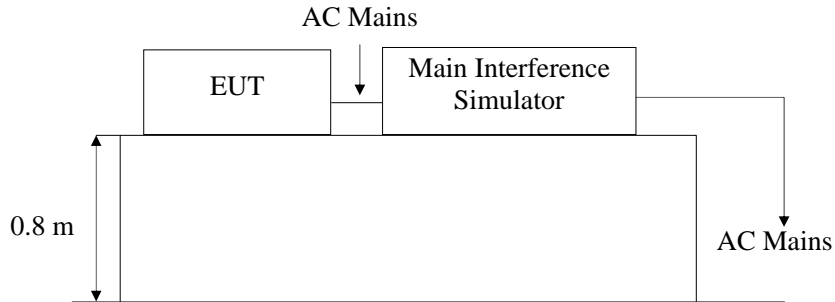

Remark: Combination wave generator and decoupling network are included in test generator.

14.2. Test Standard

EN61326-1:2006 (EN61000-4-11:2004)

14.3. Severity Levels and Performance Criterion

14.3.1. Severity level

Test Level %U _T	Voltage dip and short interruptions %U _T	Duration (in period)
0	100	0.5p
40	60	5p
70	30	0.5p

14.3.2. Performance criterion : C & B

14.4. EUT Configuration on Test

The configuration of EUT are listed in Section 3.2.

14.5. Operating Condition of EUT

14.5.1. Setup the EUT as shown in Section 14.1.

14.5.2. Turn on the power of all equipments.

14.5.3. Let the EUT work in test mode (ON) and test it.



14.6. Test Procedure

- 1) Set up the EUT and test generator as shown on Section 14.1.
- 2) The interruptions is introduced at selected phase angles with specified duration.
- 3) Record any degradation of performance.

14.7. Test Result

PASS.



Voltage Dips And Interruptions Test Results

BST Testing (Shenzhen) Co.,Ltd.

<i>Applicant</i>	: IGEN TECH CO.,LTD.	<i>Test Date</i>	: Nov. 13, 2019		
<i>EUT</i>	: THREE-PHASE ENERGY METER	<i>Temperature</i>	: 22 °C		
<i>M/N</i>	: DTSD422	<i>Humidity</i>	: 50 %		
<i>Power Supply</i>	: -	<i>Test Mode</i>	: ON		
<i>Test Engineer</i>	:				
<i>Test Level</i>	<i>Voltage Dips & Short Interruptions</i>	<i>Duration (in period)</i>	<i>Phase Angle</i>	<i>Criterion</i>	<i>Result</i>
% U_T	% U_T				
0	100	0.5P	$0^\circ \sim 360^\circ$	C	PASS
40	60	5P	$0^\circ \sim 360^\circ$	C	PASS
70	30	0.5P	$0^\circ \sim 360^\circ$	B	PASS



APPENDIX I

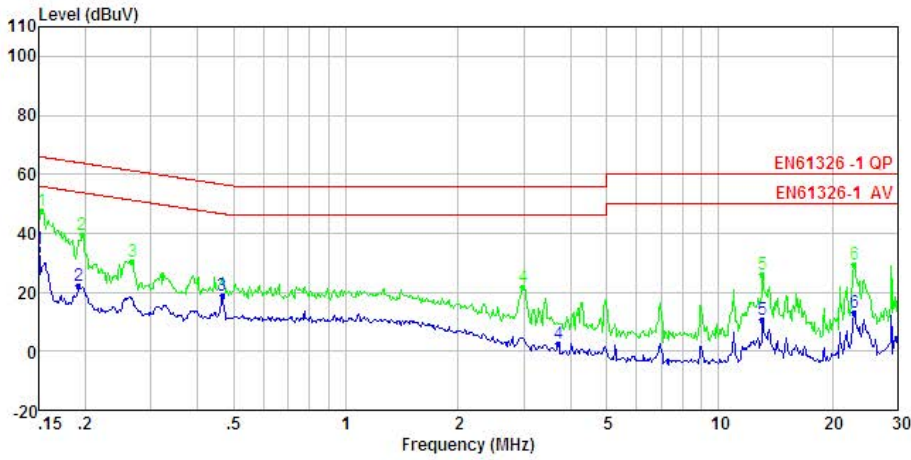

Site : Shenzhen BST Technology Co.,Ltd.
 Condition: EN61326 -1 QP
 : RBW:9.000KHz VBW:300.000KHz

	Freq	Level	Limit	Over	Remark	Pol/Phase	Level	Limit	Over	Remark	Pol/Phase
	MHz	dBuV	dBuV	dB			dBuV	dBuV	dB		
1 Max	0.150	34.5	56.0	-21.5	Average	LINE	34.5	56.0	-21.5	Average	LINE
2	0.192	22.3	53.9	-31.6	Average	LINE	22.3	53.9	-31.6	Average	LINE
3	0.466	19.0	46.6	-27.6	Average	LINE	19.0	46.6	-27.6	Average	LINE
4	3.720	2.7	46.0	-43.3	Average	LINE	2.7	46.0	-43.3	Average	LINE
5	12.988	10.7	50.0	-39.3	Average	LINE	10.7	50.0	-39.3	Average	LINE
6	22.896	13.1	50.0	-36.9	Average	LINE	13.1	50.0	-36.9	Average	LINE

Site : Shenzhen BST Technology Co.,Ltd.
 Condition: EN61326 -1 QP
 : RBW:9.000KHz VBW:300.000KHz

	Freq	Level	Limit	Over	Remark	Pol/Phase	Level	Limit	Over	Remark	Pol/Phase
	MHz	dBuV	dBuV	dB			dBuV	dBuV	dB		
1 Max	0.153	47.5	65.8	-18.3	Peak	LINE	47.5	65.8	-18.3	Peak	LINE
2	0.197	39.4	63.8	-24.4	Peak	LINE	39.4	63.8	-24.4	Peak	LINE
3	0.267	30.4	61.2	-30.8	Peak	LINE	30.4	61.2	-30.8	Peak	LINE
4	2.993	21.7	56.0	-34.3	Peak	LINE	21.7	56.0	-34.3	Peak	LINE
5	12.988	26.1	60.0	-33.9	Peak	LINE	26.1	60.0	-33.9	Peak	LINE
6	22.896	29.6	60.0	-30.4	Peak	LINE	29.6	60.0	-30.4	Peak	LINE

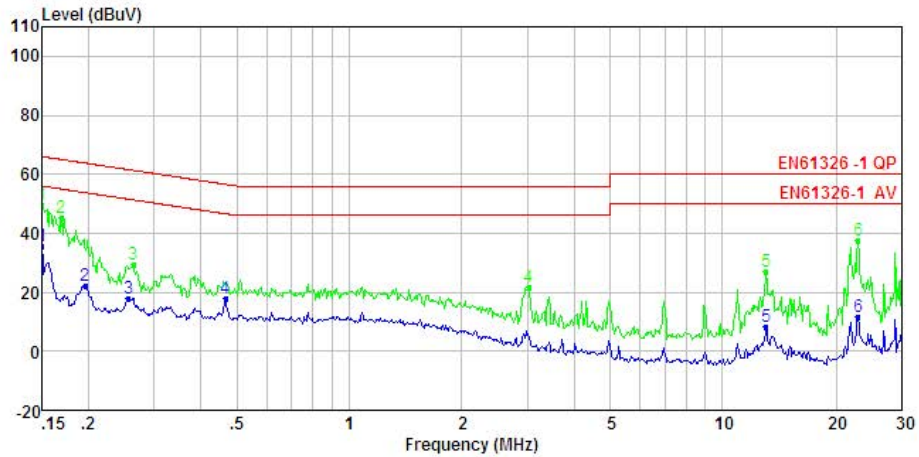

Site : Shenzhen BST Technology Co.,Ltd.
 Condition: EN61326-1 QP
 : RBW:9.000KHz VBW:300.000KHz

	Freq	Level	Limit	Over	Remark	Pol/Phase	Level	Limit	Over	Remark	Pol/Phase
	MHz	dBuV	dBuV	dB			dBuV	dBuV	dB		
1 Max	0.150	35.6	56.0	-20.4	Average	NEUTRAL	35.6	56.0	-20.4	Average	NEUTRAL
2	0.197	22.0	53.8	-31.8	Average	NEUTRAL	22.0	53.8	-31.8	Average	NEUTRAL
3	0.256	18.1	51.6	-33.5	Average	NEUTRAL	18.1	51.6	-33.5	Average	NEUTRAL
4	0.466	17.9	46.6	-28.7	Average	NEUTRAL	17.9	46.6	-28.7	Average	NEUTRAL
5	12.988	8.4	50.0	-41.6	Average	NEUTRAL	8.4	50.0	-41.6	Average	NEUTRAL
6	22.896	11.5	50.0	-38.5	Average	NEUTRAL	11.5	50.0	-38.5	Average	NEUTRAL

Site : Shenzhen BST Technology Co.,Ltd.
 Condition: EN61326-1 QP
 : RBW:9.000KHz VBW:300.000KHz

	Freq	Level	Limit	Over	Remark	Pol/Phase	Level	Limit	Over	Remark	Pol/Phase
	MHz	dBuV	dBuV	dB			dBuV	dBuV	dB		
1 Max	0.150	49.8	66.0	-16.2	Peak	NEUTRAL	49.8	66.0	-16.2	Peak	NEUTRAL
2	0.169	45.0	65.0	-20.0	Peak	NEUTRAL	45.0	65.0	-20.0	Peak	NEUTRAL
3	0.264	29.3	61.3	-32.0	Peak	NEUTRAL	29.3	61.3	-32.0	Peak	NEUTRAL
4	3.025	21.5	56.0	-34.5	Peak	NEUTRAL	21.5	56.0	-34.5	Peak	NEUTRAL
5	12.988	26.8	60.0	-33.2	Peak	NEUTRAL	26.8	60.0	-33.2	Peak	NEUTRAL
6	22.896	37.6	60.0	-22.4	Peak	NEUTRAL	37.6	60.0	-22.4	Peak	NEUTRAL



APPENDIX II

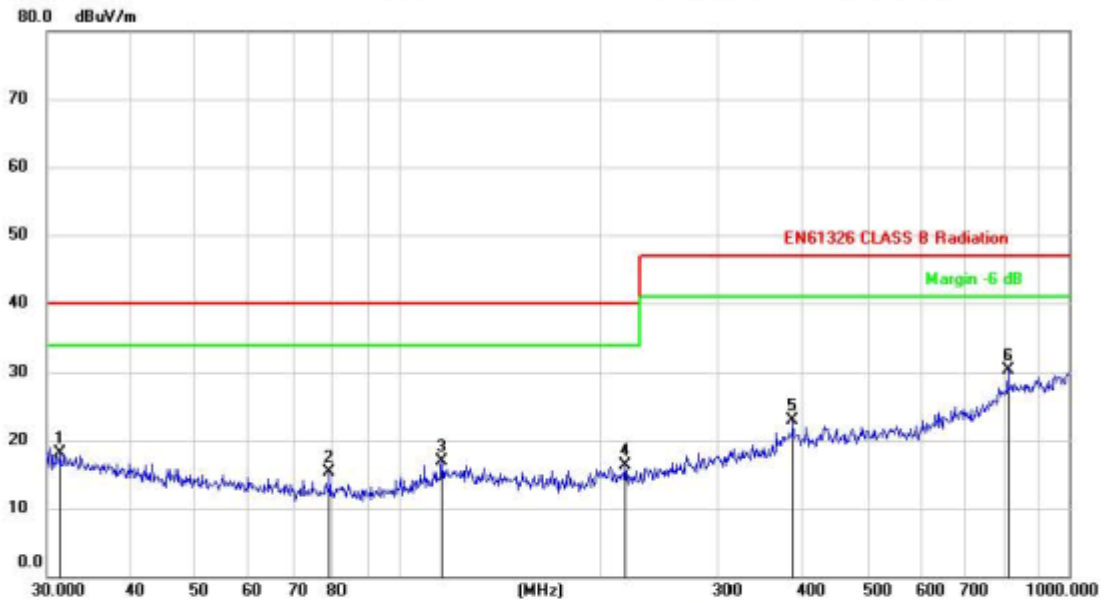

Site Chamber #1 Polarization: **Vertical** Temperature: 26
 Limit: EN61326 CLASS B Radiation Power: Humidity: 55 %
 EUT: Distance: 3m
 M/N:
 Mode:
 Note:

No.	Mk.	Freq.	Reading	Correct	Measure-	Limit	Over	Antenna	Table	
		MHz	Level	Factor	ment			Height	Degree	Comment
			dBuV	dBuV/m	dBuV/m	dBuV/m	dB	cm	degree	
1		31.3992	13.97	4.12	18.09	40.00	-21.91	QP		
2		79.2425	15.32	-0.02	15.30	40.00	-24.70	QP		
3		116.1320	14.67	2.14	16.81	40.00	-23.19	QP		
4		218.3085	14.90	1.50	16.40	40.00	-23.60	QP		
5		386.6338	16.20	6.75	22.95	47.00	-24.05	QP		
6	*	810.2653	17.47	12.93	30.40	47.00	-16.60	QP		



APPENDIX III

Photo 1 General Appearance of the EUT



Photo 2 General Appearance of the EUT



Photo 3 General Appearance of the EUT



Photo 4 General Appearance of the EUT

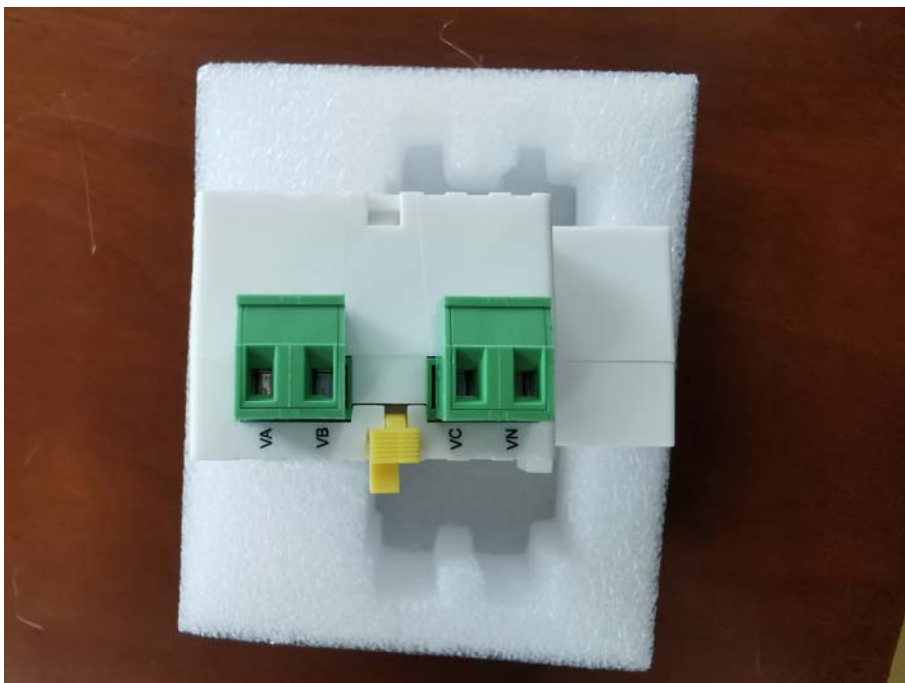

Photo 5 General Appearance of the EUT

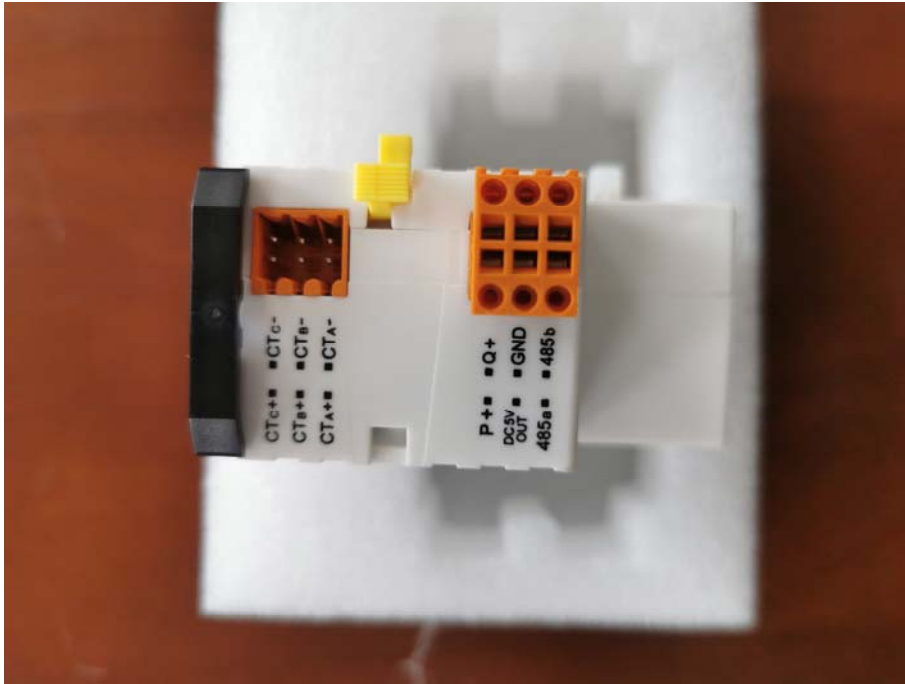

Photo 6 General Appearance of the EUT

